



# New South Wales Bridge Association

♠ ♥ Newsletter ♦ ♣

Editor: Steve Hurley

## Chairman's corner

As I write, 22 NSW teams are about to head to the GNOT National finals in Tweed Heads so we wish them all well. While that is going on, many clubs will also be hosting sessions of the final of the new NSW Under 100MP event on 29 November. This will be scored across the State, with prizes in multiple categories. Good luck to all taking part.



In November I attended the ABF Council's mid-year meeting (each State has 2 representatives on the ABF Council) at which the ABF's ongoing strategy for the next few years was discussed. This is planned to include several programs to provide more assistance to clubs across the country. More information will be made available when implementation plans are further advanced.

The NSWBA AGM is coming up on 9 December which will finish an eventful year for us after the merger of club sessions with Sydney Bridge Centre in April. The new NSWBA Council will be elected at the AGM although some of the Special councillors who represent the regional areas are already known (there being a different procedure to elect them). We will see several changes next year - Bruce Tier is replacing Graeme Payne in the Northern zone, Helen Milward is replacing Louis Koolen in the Outer Metro

zone and, as I write, an election taking place in the South/West zone to elect a Councillor to replace Dave Reddel. Many thanks to all those who have served in the past, and to all those who have shown the willingness to get involved next year.

As it's only a month to Christmas let me close by wishing everyone a happy festive season.

Happy bridging

Julian Foster  
NSWBA Chairman



## The Veterans Pairs 2015

The inaugural Veterans Pairs was held from 10-12 July at Bowral Golf Club, otherwise known as 'The 19<sup>th</sup> Hole'. The matchpoint pairs was a wonderful event, a well-run competition for the over seventies. We are most grateful to Rob Ward, the event organiser, and to the tournament director, Tony Howes, for doing a great job. Great camaraderie between the players and excellent bridge also made for a most enjoyable weekend.

My partner John Brockwell and I were leading for some part of the 3-day tournament but this good fortune came to an abrupt halt on the second last round when we played the eventual winners, Bernice and Ross Folkard.

I have come away from the Veteran Pairs with three particularly memorable hands in mind that I would like to share with you.

The first of these deals was as follows:

♠Q983 ♥KJ76 ♦52 ♣874		♠KJ5 ♥A93 ♦K7 ♣AKQ53
♠A76 ♥42 ♦QJ9863 ♣J2		♠T42 ♥QT85 ♦AT4 ♣T96

South	West	North	East
P	P	P	1♣
P	1♦	P	2NT
P	3NT	All pass	

John was seated East and I sat West. South was the dealer and passed. I passed too, as did N. John opened the bidding 1♣ in last position and I responded 1♦. After hearing my partner's rebid of 2NT, I had no trouble adding the extra to bid 3NT.

The lead was the 5♥. John surveyed the dummy. He could see that the opponents could take three heart tricks plus the A♦. Playing safely and simply cashing his winners, John would make the contract with only nine tricks, just like everyone else in the room. As this was a Matchpoint Pairs event, where it is vital to avoid a lacklustre 50%, my lateral-thinking partner pondered the best means of distinguishing himself from the field.

Upon consideration, he won the first heart and proceeded to run five rounds of clubs in order to put great pressure on the opponents to find discards. During the play of the five club rounds, John was kindly informed by his opponents of the location of the Q♠ and the A♦. He played the low diamond from his own K7 holding towards the queen on the table. This got ducked. He then took the spade finesse, rewarding him for his expert play with a well-deserved Matchpoints score.

Here for another interesting board. John sat North, and I was seated South. My partner was the dealer, with EW vul.

♠T8765 ♥T3 ♦AKJT ♣K5		♠K2 ♥Q9 ♦Q843 ♣QT976		♠AJ9 ♥AK7654 ♦52 ♣83
♠Q43 ♥J82 ♦976 ♣AJ42				

The bidding proceeded as follows:

North	East	South	West
1♠	2♥	2♠	P
P	X	P	P
P			

The lead was the 5♦ and this smelt very much like a singleton. John could see that he had to lose three spade tricks at least and two hearts and that the Q♦ would be in the pocket. After careful play we wrote down 2♠X making: +470 to the good guys.

This hand raises an interesting issue for E: to bid again or not to bid. Just think about it! When you make a double in the East position here, it normally signifies takeout. I believe that East should have passed and given partner a further chance. An alternative for those of a gambling disposition would be to bid 3♥.

It is worth remembering too that it is vital to open with sufficient points at all times to prevent disasters and partnership disagreements. All too often there are players insisting on opening 11 count hands with four controls instead of being wise enough to pass in the first instance. Then when partner turns up with a full opening hand, it is too late. The pair reaches game. Most of these contracts fail. Declarer's angry/sad/despairing face says it all – don't do this to me, partner!

Now for a defensive hand from the event. John was once again seated North, and I was South. The dealer was W, with all vul.

♠KJ93  
♥Q542  
♦86  
♣T65

♠Q2                    ♠T8754  
♥KJ63                ♥7  
♦AJ53                ♦KT74  
♣AKJ                 ♣Q94

♠A6  
♥AT98  
♦Q92  
♣8732

The bidding proceeded as follows:

<u>West</u>	<u>North</u>	<u>East</u>	<u>South</u>
1♦	P	1♠	P
2NT	P	3NT	All pass

West opened 1♦, John passed, and East with his 5 high card points bid 1♠. I passed, and West rebid 2NT, creating a problem for E. What would you do? If you pass when you have already overbid your hand and partner then makes nine tricks, you've just lost her. If you bid 3NT and the contract is defeated, partner will not be pleased and, once again, the only thing you'll see at the end of the day is her retreating back. So you are between a rock and a hard place. What to do? You decide to bid 3NT and hope to be forgiven if it is wrong.

East's train of thought must have taken him in much the same direction, as he made the decision to bid 3NT.

Would you have responded 1♠ or passed 1♦? Most good bridge players who make the first bid will probably also bid 3NT because of the K♦.

My own preference is not to respond initially. However if partner had opened the bidding 2NT (21-22), I would of course bid 3NT.

Our pair had something of a heated discussion after we took the contract four off. East said that every good modern bridge player responds on this hand. He accused declarer of misplaying the hand. She was not amused.

When dummy went down, declarer searched the ceiling with her eyes looking for divine assistance. Unfortunately it was not to prove forthcoming.

We first played three rounds of hearts, starting with a heart to the ace. I next played the 10♥ to indicate a holding in spades (on the bidding John could see that there was just enough room for me to also hold the ace in this suit).

The 10♥ was ducked by declarer. My 9 (played in preference to the 8 to send a second message to partner about my spade holding) was covered by the jack and overtaken by the queen. My partner returned the 3♠ to my ace.

During the play of these cards, declarer let go a little spade from dummy and then thought another small spade wouldn't hurt. The result was that we ended up taking four spade tricks as well.

By this time declarer had lost so many tricks that she became flustered and decided, quite unnecessarily, to take a diamond finesse. She misguessed this and further disaster ensued.

John and I don't take any credit for this good result. In the final analysis, the root cause of the problem was the initial response with only 5 points.

All in all, the Veterans Pairs was a great event. Thanks again to everyone at Bowral Bridge Club for making us feel so welcome!

We ask all over seventies to return next year to soak up the great scenery and restaurants around Bowral and Mossvale while enjoying some excellent bridge. In 2016 the congress will be held from 17-19 June. This event is a must for your calendar! Not only will you enjoy meeting your friends and playing your favourite game at a high level and but you will also find this mid-year season a perfect time to visit Bowral. So don't forget to get your entry in early!

Bill Hunt

## GNOT Metropolitan Final 2015

The Sydney Metropolitan Final was played over the weekend of 10-11 October, in its usual format of a knockout section qualifying two teams to the national final, with a Swiss repechage qualifying another two teams. Those qualifying from the knockout were decided by lunchtime on Sunday, while everyone else played through the afternoon, thus completing 8 × 14-board matches.

This year, numbers were down slightly, with 40 teams including 4 direct entries. The qualifying teams from the knockout were KLINGER (Ron Klinger, Terry Brown, Avi Kanetkar, Peter Buchen, David Beauchamp, Kim Morrison) and CHYLEWSKI (Witold Chylewski, Linda Aubusson, Titus Ling, Ranjit Limaye). The top two teams from the Swiss were BOCK (Steven Bock, Rakesh Kumar, Gary Lane, David Smee) and HOOGERVORST (Carola Hoogervorst, Andre Korenhof, Sophie Ashton, Helena Dawson, Maurits Van Der Vlugt, Sartaj Hans).

Early on Saturday, Round 2 was full of interesting hands. This one was amusing:

Board 17	♣KT3		
Dealer N	♥AT754		
Vul None	♦A7542		
	♣		
♠AJ7654		♠Q92	
♥KJ6		♥Q3	
♦		♦QJT963	
♣K875		♣A3	
	♠8		
	♥982		
	♦K8		
	♣QJT9642		

East-West routinely reached 4S after North-South competed in hearts. At our table, North cashed A♥, then continued a low heart. I overtook Q♥ with K♥. It looked easy: ruff 2 clubs in dummy and 11 tricks ought to be readily available on any reasonable trump break. So I led a low club towards dummy – and North ruffed! Back came A♦ and now it was my turn to ruff! I then played the J♥ discarding the A♣ from dummy, ruffed a club, ruffed a diamond, ruffed another club and ran the Q♠, losing to North's king but making 10 tricks. Around the room, 12 pairs bid and made 4S, 10 pairs went off, while 5 East-West pairs collected extra IMPs when North-South competed to 5H and were doubled.

From the same round, this was a difficult-to-reach 4S:

Board 27	♠KT7		
Dealer S	♥5		
Vul None	♦AJ842		
	♣K765		
♠AQ		♠95	
♥QJ986		♥43	
♦KQ76		♦T953	
♣AJ		♣QT984	
	♠J86432		
	♥AKT72		
	♦		
	♣32		

If South opens with a weak bid showing both majors, there are good chances of reaching 4S. With trumps 2-2 and the A♠ and A♣ favourably placed, all that is needed is one ruff in the North hand. However, of 17 pairs that bid the game, only 8 were successful.

Yet another hand from round 2 reinforced the notion that leading a singleton trump is often not a good idea:

Board 28	♣J42		
Dealer W	♥JT82		
Vul N-S	♦872		
	♣964		
♠863		♠AQT5	
♥Q73		♥AK954	
♦KJ3		♦Q96	
♣KJ73		♣2	
	♠K97		
	♥6		
	♦AT54		
	♣AQT85		

After 1H by East and a 2C overcall by South, I bid 2NT, which partner raised to game. The 9♣ was taken by the jack and a diamond played to the queen, won by South's ace. I won the club return with the king, played a heart to the ace and then discovered the 4-1 break on a heart back to the queen. This now meant I had to concede a heart to North to make 9 tricks, but the contract was still cold. However, 17 EW pairs were in 4H and this is *not* cold on normal play (Deep Finesse knows to lead

low towards the AK♥ and insert the 9♥ if North does not split his honours, but most humans wouldn't do that). The 12 declarers who received a low heart lead had their problem solved.

Round 3 featured not one but two grand slam hands! The first was essentially a bidding exercise:

Board 4      ♣AQ854  
 Dealer W     ♥K64  
 Vul Both     ♦AQ  
                  ♣985

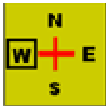
♠J632		♠T97
♥T9832		♥Q
♦KT9		♦J876432
♣7		♣JT

♠K  
 ♥AJ75  
 ♦5  
 ♣AKQ6432

Playing a strong notrump with 5-card majors, 1NT-2C-2S leaves it up to South to take appropriate action. This doesn't seem too difficult, yet only 7 pairs reached a grand slam, 4 in 7C and 3 in 7NT. Would you have got there?

The other grand slam was more of a challenge:

Board 11     ♣984  
 Dealer S     ♥QT5  
 Vul None     ♦QT8762  
                  ♣8

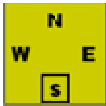
♠T63		♠AKJ
♥A983		♥6
♦AK3		♦J5
♣AT2		♣KQJ9765

♠Q752  
 ♥KJ742  
 ♦94  
 ♣43

This time West opens a strong notrump and if East bids 3C showing slam interest, inviting a cue with good support, things will get rolling. East can then discover that all the keycards are held, plus the K♦. While that might be enough to induce a bid of 7C,

there's more to the story. On any lead other than a spade, East needs to avoid having to finesse, so must play for a squeeze. Say the lead is a trump. The A♥ is cashed, a heart is ruffed, back to dummy with a trump for another heart ruff, and when the Q♥ drops declarer must now hope that one defender is left guarding both majors. She plays off all her trumps and crosses to the A♦ with these cards remaining:

♠		♠
♥immaterial		♥
♦		♦
♣8		♣8

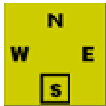
♠T6		♠AKJ
♥9		♥
♦A		♦J
♣		♣

♠Q75  
 ♥K  
 ♦  
 ♣

On the last diamond, South cannot keep a top heart and 3 spades, so 7C makes. Eleven pairs bid grand slams (some in 7NT) but 5 of these went down.

In our match, 7NT was bid and made at both tables on board 4, and 7C at both tables on board 11, so there was no swing on either hand!!

Round 3 also featured this potentially exciting hand:

Board 10     ♠T  
 Dealer E     ♥K65  
 Vul Both     ♦KQT82  
                  ♣AK97

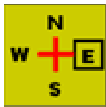
♠72		♠AJ543
♥J98432		♥AQ7
♦76		♦J4
♠T62		♣Q53

♠KQ986  
 ♥T  
 ♦A953  
 ♣J84

We were playing a 14-17 notrump with 5-card majors so East opened 1NT, South bid 2S showing spades and a minor and North converted to 3NT, which was unbeatable. Another 6 North-South pairs

played in 3NT and 3 in 5D making, while others made assorted part-scores. However, things often turned out very unhappily for those Easts who opened 1S – a dozen ended up 1S doubled, usually going down quite a few, sometimes for a 4-digit number.

Much later, in Round 7 on Sunday afternoon, there was this exciting hand:

Board 9	♣T95		
Dealer N	♥85		
Vul E-W	♦KJT765		
	♣K4		
♠J2		♠KQ873	
♥AKQT73		♥J62	
♦AQ4		♦983	
♣J3		♣QT	
	♠A64		
	♥94		
	♦2		
	♣A987652		

A lot depended on the action taken by North-South. At our table, North opened proceedings with 3D, passed around to me. I bid 3NT and North led a diamond to my queen, so at trick 2 I played a low spade towards dummy's honours, hoping that whoever held the ace would duck. When the K♠ held, I tabled my hand, claiming another diamond trick and 6 hearts. At the other table, North passed and South pre-empted 3C, which ruled out 3NT as a possible contract. West therefore bid 4H, but North raised the stakes by continuing to 5C. When East then bid 5H and NS defended accurately, this was 3 off for a net swing of 14 IMPs, which proved to be the margin of the match. Whew!

Rakesh Kumar

## 2015 State Open Pairs

The NSW State pairs was conducted at in NSWBA in Goulburn St over the weekend of the 14 and 15 November. While pairs could enter directly, the event included pairs from the city and country that qualified through a local event. 68 pairs took part, and the final was held on the Sunday, with two 7 table finals for the State pairs and Country pairs.

There were the fair share of interesting hands. The following hand shows the importance of thinking options through.

As South, you hold:

♠6  
♥AT875  
♦J62  
♣K865

The auction proceeded 2D by North (partner) showing a weak two in a major or a big balanced hand. Then East overcalls 4H. Do you double or do you pass?

This is pairs. It is likely to go down. You have great H pips (usually crucial when deciding to double or not), hopefully a C winner, and partner should have something vul against not for the opening 2 bid. So you elect to double to get the better matchpoint score. (Doubling in teams would not be particularly worthwhile as you may just pick up an extra 50 while giving away 170).

You lead your 6♠. Dummy comes down:

Dummy  
♠K532  
♥3  
♦KT73  
♣J943

You  
♠6  
♥AT875  
♦J62  
♣K865

Partner plays the T♠, and declare wins with the A♠. Declarer leads the J♥ which you duck in case partner has something higher. Expectedly the J♥ wins, and the Q♥ is played. You win, and partner plays a card to indicate no preference for either minor suit. Your go.

With partner showing no preference, this means either nothing in those suits (unlikely given partner has only shown 3HCPs for the vul weak 2 bid), two Queens, or 2 Aces. If partner has the Aces, it does not matter. But if partner has the Queens, you have to find the right switch. The important point here is if you lead a ♦ here you will expose your J♦ to a finesse later. So the correct play is a small ♣.

Here is the full hand:

**Board 21** ♠QJT874  
*Dealer N* ♥6  
*Vul N-S* ♦Q4  
 ♣QT72

♠K532		♠A9
♥3		♥KQJ942
♦KT73		♦A985
♣J943		♣A

♠6  
 ♥AT875  
 ♦J62  
 ♣K865

Yes, partner may have the 9♦ but regardless, a ♣ will produce a ♣ trick along with two ♥ and a ♦ trick for one off.

Another hand. South, you hold the usual rubbish:

♠J654			
♥T653			
♦T743			
♣4			

<u>East</u>	<u>South</u>	<u>West</u>	<u>North</u>
1♣	P	1♥	P
2♣	P	3♥	P
3NT	All pass		

Your lead. Which suit is your best option? Partner expectedly has quite a few points because the opposition have not explored past game. So why no bid from North? Anyway, with nothing standing out, you lead the 4♣. And dummy spreads:

Dummy  
 ♠Q7  
 ♥AKJ942  
 ♦K2  
 ♣T87

You  
 ♠6  
 ♥AT875  
 ♦J62  
 ♣K865

Declarer plays the Q♠, partner plays the K♠, and this wins. North returns the T♠, declarer plays the 9♠, and you play small. Another ♠ forces the A♠. You could unblock the J♠ if you wanted partner to be on lead, but in this case, you want to lead through to partner's points. To try for the ♣ finesse, declarer attempted a ♦ to the K♦, but this was taken by partner's A♦. Then the last ♠ is played to you. Looking to just exit and not finesse partner, you play another ♦ which partner wins with the Q♦ and returns 8♦. Declarer win this with the J♦ and bangs down the A♣ then Q♣. Partner wins this with K♣ and returns a third ♣ locking declarer in hand. After the runs of clubs, had to concede one more trick, the last ♦. Declarer made only 6 tricks. Not too bad from your motley collection of Tens and a Jack.

This was the full hand.

**Board 2** ♠KT83  
*Dealer E* ♥Q87  
*Vul N-S* ♦AQ8  
 ♣K93

♠Q7		♠A92
♥AKJ942		♥
♦K2		♦J965
♣T87		♣AQJ652

♠J654  
 ♥T653  
 ♦T743  
 ♣4

The scores on the hand range from 150 NS to 490 EW, 3NT making 12 tricks. That's a variation of 6 tricks! The difference is who declares the hand. If West plays the hand, the Q♠ is protected, and on a ♠ (quiet reasonable given North's hand and the bidding), West can gain the lead, finesse the K♣, and poor North will be severely embarrassed on the run of the clubs.

The results for the 2015 State Open Pairs were:  
 1<sup>st</sup> - Sophie ASHTON - David WILTSHIRE  
 2<sup>nd</sup> - Tom GOODYER - William WESTWOOD  
 3<sup>rd</sup> - Tony NUNN - Martin BLOOM

The results for the 2015 State Country Pairs were:  
 1<sup>st</sup> - Catherine CHOWN - Chris BAYLISS  
 2<sup>nd</sup> - Emil BATTISTA - Ian WALKER  
 3<sup>rd</sup> - Jeff CARBERRY - Kaye HART



On the Sunday, the Spring Swiss Pairs was also played, as a separate event running adjacent to the two finals. 7 rounds of 8 boards were played using a pairs type format but with teams scoring. While normally there is a degree of jostling for final positions, Donald Knaggs and Albert Tjahja headed the field in round 5 and stayed there to win the event. 2<sup>nd</sup> Second were Elizabeth Adams and Andrew Peake, and third were Lavy and Tomer Libman.

Steve Hurley

## The hazard of interruptions

Interruptions have their own unique effect on the game. You need to concentrate on what is being said then you need to pick up the thread of what is happening at the table. Ideally, announcements should not be made during play, but if they are, for players, everyone should just stop at a logical spot, put the hands down, then recap actions to date when play restarts.

In a local congress event, playing teams, as West you pick up:

♠A95  
♥J543  
♦T54  
♣762

The bidding proceeds:

N	E	W	S
1D	P	1H	P
3H	P	4H	All pass

Looking at nothing better to lead, you lead 6C. Dummy comes down:

Dummy  
♠Q2  
♥KQT2  
♦AQ873  
♣98

You  
♠A95  
♥J543  
♦T54  
♣762



Partner wins the K♣, plays the Q♣, then the A♣. You play MUD so partner knows you have three clubs, and dummy ruffs with the 2H. Sweet! Looks like another 2 tricks to you.

Then the announcement from the Director .... We all put our cards into the board except dummy.

'... the next session will start at 1.30 .... lunch will be in the other room ....', and so on for a minute or so.

We retrieve our cards and off we go. The lead is in dummy. The K♥ is played, all follow, and the lead is still in dummy. Q♥ is played, and you now rejoice looking at two tricks to scuttle the contract. What could go wrong? Partner follows?!?

That means declarer has bid on a three card ♥ suit? I look at declarer for telltale signs if he had inadvertently picked out the wrong bidding card. But declarer's face is focused. Nothing there.

The 10♥ is played, partner follows, again?!?

A♥ is won by south. Declarer now plays K♦, J♦, and starts to run the diamonds. With several tricks to go, partner leans forward and proudly announces they he has the rest of the tricks with the remaining high trumps. This is disputed by declarer saying he has a trump, and I am still looking at my master trump.

After the smoke has cleared, I noticed that the back of partner's card was blue and everyone else was red. Partner was thinking about lunch and inadvertently pulled the cards from the wrong board.

Two boards were scrapped, the one played, and the one from which partner had pulled the wrong cards. But we did get to lunch before the milling throng descended.

Steve Hurley

## The NSW Country Carnival

The Country Carnival is a moving feast of bridge for the country players in NSW. Last year it was in Sydney (coinciding with the ANC) and this year it went to Port Macquarie, ably managed by Louis Koolen from the Central Coast.

Renate La Mara, winner of the restricted event reports...



Attending the Country Carnival Restricted Pairs event we would like to thank the people responsible for putting this event on the calendar. It is a great platform for players from country areas around NSW to get some experience in competing at tournaments.

It was a delight to meet bridge players from as far afield as Port Macquarie and exchange ideas and experiences. We had a wonderful weekend even allowing for a horrible start with a blown tyre 70 km before Newcastle (coming from Wollongong). Being the long weekend and with the car needing particular type of tyre, we needed to backtrack to Tempe in Sydney. So a 6 hour trip took 14 ½ hours.

The friendly people from Port Macquarie/Hastings Bridge Club made up for the nightmare the next day. Handcrafted table number cards greeted us at each table. There were flower arrangements on display everywhere. The Port Macquarie/Hasting Bridge Club put on a wonderful tournament with great food. I am not very far travelled in bridge circles, so if your club provides excellent food, invite me to your next event. Bridge and food go together amazingly well.

I wish more of my fellow bridge players would have been able to make the trip to the Country Carnival and share the wonderful experience of meeting fellow country bridge players. I can only recommend this tournament to every emerging or established bridge player and the generous travelling subsidy makes it very affordable.

Lastly I would like to add that our trip home was uneventful, even allowing for the constant 36 degree heat in a boy-toy car with no air conditioning.

I recall one hand though. You sit South.

♠43	Board:5
♥AT64	Dealer: N
♦QJ765	Vul: NS
♣A6	
♠KT5	♠J862
♥KJ5	♥92
♦A9843	♦2
♣KQ	♣987532
♠AQ97	
♥Q873	
♦KT	
♣JT4	

The bidding proceeded as follows:

<u>North</u>	<u>East</u>	<u>South</u>	<u>West</u>
P	P	1♣	1NT
X	P	P	2D
X	P	3NT	All pass

The initial pass by partner North is a little unusual but we had decided to be conservative with initial bids – we let opposition get into trouble.

The double by North of a 1NT overcall is for penalty. When the bidding came back to West, he corrected to 2D and partner North doubled again.

This is not a common auction. Is the second double for takeout??? Partner must be strong to double again. If I leave the double in and they go 2 off not vul, that's 300, and 3 off 500. If we can make 3 NT we'll score 600. Declarer play is easier than finding the right defense, so 3NT was bid by South.

The other pairs were all in Hearts. Some in 4H, some making, and more in 3H usually making. Bidding 3NT was just easier and as South I knew where all the cards were. *(Ed. And West would be embarrassingly end-played many times for 9 or 10 tricks.)*

Renate La Mara

## Blackwood and friends ...

Blackwood is arguably the simplest method of exploring slam opportunities, and since its inception in 1933 (yes, it's been around that long), there have been derivatives that have been very helpful in different situations.

### Traditional Blackwood

Firstly the basic form. 4NT, it asks partner 'How many aces do you have?' Partner responds with bids as following:

5C – 0 or 4
5D – 1
5H – 2
5S – 3

After the response, 5NT by the 4NT bidder asks for kings in a similar manner:

6C – 0
6D – 1
6H – 2
6S – 3
6NT - 4

## Roman Key Card Blackwood (RKCB)

As with most simple conventions, better derivations have been developed. Roman Key Card Blackwood explores slams looking also at the K of trumps as a key card, as well as the Q of trumps. This is based on an agreed trump suit. (If no suit is agreed, the traditional form is used.)

4NT – asks partner how many of the 4 aces and K of trumps that you have (and perhaps the Q of trumps).

Responses:

- 5C – 0 or 3
- 5D – 1 or 4
- 5H – 2 without the Q of trumps
- 5S – 2 with the Q of trumps

After the response, 5NT asks for kings in the same manner as simple Blackwood:

- 6C – 0
- 6D – 1
- 6H – 2
- 6S – 3

### Variations - a different King ask

Instead of using 5NT as the King ask, if the asker bids the next suit up, it is the King ask. The responses are based on the same steps as those used had 5NT been the K ask. That is, the first step is 0 kings, the second step is 1 King, and so on.

For example:

West	East	
1S	3S	
4NT	5D	<sup>1</sup> King ask
5H <sup>1</sup>	5S <sup>2</sup>	<sup>2</sup> 0 kings (first step)
Pass		

If you have agreed say Hearts as trumps and partner responds 5D, then the next suit up will be 5S in this instance. 5H by the 4NT bidder will be to play.

### Variations - a different King ask as well as asking for the Queen of trumps

A better variation of this is to incorporate a check for the Q of trumps as well into the ask for Kings. This would only apply if the responder has bid 5C or 5D (otherwise the responder has already shown the Q of

trumps or not with bidding 5H or 5S). The first step denies the Q trumps, the second step shows the Q of trumps as well as 0 kings, the third step shows the Q of trumps as well as 1 king, the fourth step shows the Q of trumps as well as 2 kings, and so on.

For example:

West	East	
1S	3S	
4NT	5D <sup>1</sup>	<sup>1</sup> 1 or 4 key cards
5H <sup>2</sup>	6C <sup>3</sup>	<sup>2</sup> Q of trumps and King ask
6S		<sup>3</sup> Q♠ + 1 king (3 steps)

If the asker instead bids 5NT after the initial 4NT RKCB ask, then this is asking purely for Kings.

West	East	
1S	3S	
4NT	5D <sup>1</sup>	<sup>1</sup> 1 or 4 key cards
5NT <sup>2</sup>	6D <sup>3</sup>	<sup>2</sup> King ask
6S		<sup>3</sup> 1 king (2 steps)

This also implies that knowing about the Q trumps is not required (because the asker has the Q trumps).

### Variations - Economising bidding space

With the above structure, bidding 5D show 1 or 4. Most of the time when looking for slam, responder will have 1 of the key cards rather than none of them. So some partnerships have swapped the 5C and 5D bids around. This now means RKCB is =>

- 5C – 1 or 4
- 5D – 0 or 3
- 5H – 2 without the Q of trumps
- 5S – 2 with the Q of trumps

This now allows a little more room in some auctions to explore further when using the next suit ask. Sometimes this is helpful where you could stop in say 5H. For example=>

West	East	
1H	3H	<sup>1</sup> 1 or 4 key cards
4NT	5C <sup>1</sup>	<sup>2</sup> Do you have the Q
5D <sup>2</sup>	5H <sup>3</sup>	trumps, and if yes,
Pass		how many Kings?
		<sup>3</sup> No Queen of trumps

If 5D showed 1 or 4, then the next cheapest bid would have been 5S (5H would be to play), and this means playing in 6H when partner denies the QH. So swapping the bids has some advantage.

## Blackwood for the minors

Those dreaded minors, often playing at the 6 level one off when partner gives the wrong response. But boffins have worked out better ways of exploring this (without the use of Gerber which is just confusing when looking for slams in Clubs). It's not Blackwood, it's 'Redwood'.

Typically this involves the use of other four level bids as an ask instead of 4NT. Once the minor suit has been agreed, bidding the suit above agreed trump suit at the 4 level is RKCB. For example =>

West	East	
1C	3C	
4D <sup>1</sup>		<sup>1</sup> RKCB
.... or ...		

West	East	
1D	3D	
4H <sup>1</sup>		<sup>1</sup> RKCB

So after agreeing Clubs, 4D is RKCB, and if Diamonds are agreed, 4H is RKCB. All responses to these RKCB bids are shifted down by the same levels of bidding. So **IF** you would you have used normal 4NT RKCB, partner **WOULD** have responded 5H, which is three steps. If Clubs is the agreed trump suit, then 4D is RKCB. Three steps after 4D is 4NT. This now shows 2 key cards and denies the Q of trumps. You can now stop in 5C if needed. Or you can now continue on exploring higher, by using the RKCB asking suit at the 5 level (5D in this case) to ask for Kings. This again allows for stopping lower, in 6C.

Why is it called 'Redwood'? Because it uses the two red suits to ask for key cards.

## Kickback

Kickback basically takes the idea of Redwood & applies it to all suits, for the same reason of saving room.

Once **ANY** suit has been agreed, bidding the suit above agreed trump suit to the 4 level is RKCB. In other words –

- If clubs is agreed, 4D is RKCB
- If diamonds is agreed, 4H is RKCB
- If hearts is agreed, 4S is RKCB
- If spades is agreed, 4NT is RKCB

Again, responses will be the same but shifted the appropriate level of bids down.

## Blackwood and voids

Arggh. "I have a void and if I ask for aces. If I use RKCB, how do I know that the ace partner has is not in the suit where I have a void?" A common complaint.

Enter "Exclusion Blackwood".

Once a suit is agreed, this is a bid at the 5 level in another suit, telling partner "Ignoring the suit that I have bid, tell me how many key cards that you have." This also tells partner that you have a void in this suit and that any information you now tell partner will be suits that he has, with cards useful for filling gaps in these suits. The responses are the same as normal RCKB.

For example =>

♠AQJ963	♠K742
♥KQ8	♥J63
♦-	♦A752
♣KJ74	♣A8

West	East	
1S	3S	<sup>1</sup> Excluding diamonds, show me your key cards
5D <sup>1</sup>	5NT <sup>2</sup>	<sup>2</sup> I have 2 (KS and AC), without the Q trumps
6S <sup>3</sup>	Pass	<sup>3</sup> Damn!

Swap the AD for the AH in the East seat ...

♠AQJ963	♠K742
♥KQ8	♥A63
♦-	♦J752
♣KJ74	♣A8

West	East	
1S	3S	<sup>1</sup> Excluding diamonds, show me your key cards
5D <sup>1</sup>	6C <sup>2</sup>	<sup>2</sup> I have 3 (KS, AH, AC)
7S <sup>3</sup>	Pass	<sup>3</sup> Yippee!!

## **So many options ...**

By now you will be thinking 'this is all very confusing'.



The key to any partnership is to have solid and understood agreements, robust in the heat of battle, so that there is trust in the bids made and they are consistent. Take from above then elements of the different versions, to develop a level of Blackwood that is comfortable between you and your partner. This will provide you with the basis for ongoing enjoyment over the games to come.

But if you are thinking about a preferred method, perhaps the optimal combination will be Kickback with exclusion Blackwood.

### Gerber

'What about Gerber?' some people will be musing. Gerber is simple and works well, but there are just too many horror stories when clubs are trumps, there is an attempt to show another suit, or cue bidding starts. From experience, Gerber with basic Blackwood responses should only be used over No Trump. (This allows also for 4NT as a quantitative invite to 6NT.) Simple, with no ambiguity. Otherwise, for agreed suits Kickback works well to stop at the 5 level.

Steve Hurley

### From little acorns do big trees grow ...

After an auction best consigned to the waste paper bin, you arrive in a tricky contract of 6S. Tricky because you are missing two Aces! The A♣ is lead and you see =>

♠AK43  
♥KQ7  
♦K98  
♣842

♠QJT87652  
♥2  
♦A5  
♣KJ

The hand will be over if your left hand opponent continues a ♥. But at trick two, Q♣ was continued. How do you chart a possible path to 12 tricks?

You know the A♥ is on your right (else it would have been played). There is not much in the way to set up as long suits. But you do have a remarkably long ♠ suit and on the run of these, the opposition will be under enormous pressure with discards. And the prime requisite for a squeeze has occurred – you have lost the necessary amount of tricks and cannot lose any more.

Just keep running the Spades .... The 8♣ in dummy will be a threat to the left hand opponent. The hearts in dummy are no good to you discard those. And with one spade to go, the hand looks like this.

♠ -  
♥ -  
♦ K98  
♣ 8

♠ -	♠ -
♥ -	♥ A
♦ QT4	♦ J76
♣ T	♣ -

♠ 6  
♥ 2  
♦ A5  
♣ -

Now lead the last Spade and look at the discards. West must play a ♦ otherwise the ♣ will be a winner. When West plays a ♦, dummy's ♣ is now not a winner so can be discarded.

East's turn. If East throws a ♦, that suit will run. East chose to discard the A♥.

Your little 2♥. A loser for all intents. It is now all grown up and becomes your contract making twelfth trick.

Ethyl Severe

### Around the State

Clubs across NSW are strongly encouraged to submit articles to the editor to promote activities, events, successes, etc, in their club. Please send articles to [editor@nswba.com.au](mailto:editor@nswba.com.au).

## Far North Coast



The Coffs Bridge Club held a special session on Saturday 26 September, for all our who members who are over 90 or in their 90th year. We feel proud and humbled to have these members, many of them still playing regularly. We managed to get them all, apart from two, at the club for Saturdays game and celebrations. They are a sprightly bunch and a credit to our club



Left to right: Joyce White, Madge Goudie, Jess Miller, Delia White, Iris Wyner, Ann Thompson, Beryl MacQuillin, Frank Bourke and Arthur Smith.  
Missing from the photo are Don and Arthur Smith

## Blue Mountains



Glenbrook Bridge Club recently had its 'usual' 3rd Sunday of the month Bridge afternoon by holding a Charity Day. This year we decided to support Ovarian Cancer Australia and were successful in raising \$863.00 through charging extra table money and holding several raffles. Many thanks to our wonderful members who continue to support our growing club and who also provided the delicious afternoon tea.



## Central West



Over the weekend of 31 October and 1 November, the Bathurst & District Bridge Club hosted their inaugural Central West Novice Tournament for bridge players with < 35 MPs.

The competition was run in 2 divisions: 0 – 10 MPs and 10 – 30 MPs, with 20 of the 70 competitors having less than 3 MPs at entry deadline and half of the overall entries less than 10 MPs.



Bathurst Regional Council officially endorsed the Tournament as a Bathurst 200 Bicentenary event providing assistance with commemorative medallions for all competitors and Bx200 badges for all place getters.





13 bridge clubs from the Sydney, Illawarra, Wagga, Canberra, Cootamundra, and Central West regions made up 30 Pairs on Saturday, 14 Teams on Sunday competing for a splendid array of prizes.



Prizes - pairs

All prizes were sponsored by regional businesses and the "Summer Festival of Bridge" donated complimentary entry into the "Super Novice" and "Rising Stars" divisions in their upcoming Canberra festival in January – heartfelt thanks to all of our sponsors.

Prizes - teams



In addition, much help came from both the ABF and the NSWBA in getting the Tournament to the starting line and providing advertising in both Newsletters.

Special thanks to Pauline Gumby who gave welcome direction and advice.

A huge amount of food disappeared over the 2 days and travelers on Sunday were sent on their way with small food hampers for their journey.

Lloyd Cleaver directed, ably assisted by a team of other club directors and members helped make the play problem free and successful – a very happy and friendly atmosphere prevailed.

Winners:

- Overall Pairs and 10-35 MPs Pairs – Thi Pham and Lynda Atkin (Springwood and Glenbrook)



Thi Pham, Lynda Atkin - Overall pairs winners with Bill Keirath and John Shield

- 0-10 Pairs - Charles McMahon and John McMahon (Wagga)



Charles and John McMahon - 0 to 10 MP Pairs winners with club president Bill Keirath and tournament organiser John Shield

- Overall Teams and 0-10 MPs Teams - Charles McMahon and John McMahon (Wagga) & Georgina McMahon and Sebastian Strugnell (Sydney) – this team’s members are all under 27 years old and provided very stiff competition.



Teams victors - John, Charles & Georgina McMahon with Sebastian Strugnell

- 10-35 MP Teams - Caroline Hermes, Heather Last, Barbara Beveridge and Annie McMaster all from Cootamundra
- Best locals
  - Pairs
    - 10 to 35 MPs – Kevin Wilds and Phil Cummings
    - 0 to 10 MPs – Bev Vickers and Jim Vickers
  - Teams
    - 10 to 35 MPs and 3<sup>rd</sup> overall - Joy Adams, John Adams, Paddy Robinson and John Shield
    - 0 to 10 MPs – Bev Vickers, Jim Vickers, Toni Pender and Val Stuart

### Overheard from the next table ...

My partner's next door neighbour is Paddy who has just returned from Ireland. Paddy was whingeing about the first time he took his son out for his first pint. Off they went to their local pub only two blocks from their house.

Paddy got him a Guinness. He didn't like it, so he drank it himself.

Next Paddy got him a Kilkenny; he didn't like that either, so Paddy drank that too.

Finally, he thought he might like some Harp Lager. His son spat it out. So Paddy drank it.

Then Paddy thought 'Hmmm, maybe he'd be liken whiskey better dan beer - so dat's what 'eal have. He tried him with a Jameson's!' Nope! Spat that out.

In desperation, Paddy asked the barman for some rare Redbreast, Ireland's finest. He wouldn't even smell it.

What a man to do but drink it! No wastage here.

By the time he realized that his son just didn't like the drink, he was so drunk that he could hardly push the son's stroller back home.

Meanwhile Muriel at table 5 was talking about her three friends who were in a car involved in an accident. The doctor was checking them out and Jean enquired "Doctor, will I still be able to play bridge?"

The Doctor asked "How many high card points in a deck of cards?"

"60!" Jean replied.

Worried, the doctor turned to Wayne "How about you? How many high card points in a deck of cards?"

"Uh, Wednesday!" he shouted.

Even more concerned, the doctor motioned to the Sheryl. "Well, what do you say, madam? How many high card points in a deck of cards?"

"Forty!" Sheryl replied.

"Excellent!" the doctor exclaimed. "How did you get that?"

"Oh, it's pretty simple," she explained. "You just subtract 60 from Wednesday!"

Then at table 2, Phil was talking about his partner who is an academic. He said that light travels faster than sound. He explained that this is why some bridge players appear bright until you hear them speak in the post-mortem.





## Congress Results

### Central Coast Novice Congress

*Pairs:* Ray Hendley, John McCaffrey  
*Teams:* Ray Hendley, Joe Conde, John McCaffrey, John Lette

### Dubbo Congress

*Restricted Pairs:* Shiela McCure, Peter Reed  
*Open Pairs:* David Lander Helene Lander  
*Teams:* Jill Beith, Bettyanne McFarland, Maureen Wright, Barbara Green

### Trumps Friendly Pairs

Toni Sharp, Kim Morrison

### Blue Mountains Bygone Beautys Congress

*Pairs NS:* Michael Wilkinson, Griff Ware; *EW:* George Finikiotis, Liz Fanos  
*Teams:* Griff Ware, Michael Wilkinson, Johnno Newman, Bob Sebesfi

### Sapphire Coast Congress

*Walkin Pairs NS:* Colin Manley, Lewis Seychell;  
*EW:* Gabrielle Wilson, Di Woolford  
*Swiss Pairs:* Stephen Mendick, Andy Creet  
*Teams:* Tim Davis, Jan Davis, Emlyn Williams, Lisa Ma

### Port Macquarie-Hastings Teams

William Powell, Marjorie Askew, Anne Jackson, Eric Hurley

### NSW Country Carnival

*Open Winners:* Sylvia Foster and Jaan Oitma  
*Restricted Winners:* Stuart Cutsforth and Renate La Marra  
*Novice Winners:* David Weatherall and Craig Curry

### Hunters Hill Teams

*Open:* Ranjit Limaye, Michael Draper, Bijan Assaee, Alexis Ngan  
*Restricted/Novice:* Guy Dillon, Holly Dillon, Robbie Carmichael, Craig Taberner

### Lismore Teams

*Open:* John Paynter, Maureen Baker, John Kable, Kay Milne  
*Restricted:* Greg Maley, Jenny Maley, Chris McDowell, Jennifer McDowell

### Great Lakes Annual Congress

*Swiss Pairs:* Ken Wilks, Michael Simes  
*Teams:* Kim Morrison, Liz Fanos, Marilyn Chadwick, George Finikiotis

### Glen Pairs

Nigel McIvor, Kellie Potts

### IBA Swiss Pairs

Johnno Newman, Matt Smith

### Mollymook Congress

*Swiss Pairs:* Allan Scerri, Susan Scerri  
*Teams:* Janet Turnell, Kevin Tant, John Brockwell, Val Brockwell

### Tamworth Swiss Pairs

Helena Dawson, David Weston

### Wollstonecraft Pairs

Heather Cusworth, Peter Jeffery

### Commercial Club (Albury) Super Congress

*Swiss Pairs:* Sean Mullamphy, Arjuna De Livera  
*Teams:* Arjuna De Livera, Sean Mullamphy, Jamie Ebery, Kim Frazer

### Tenterfield Butler Pairs

Malcolm Saunders, Ian Price

### Muswellbrook Congress

*Pairs:* Margaret Geddes, Chris Williams  
*Teams:* Janet Hill, Bernie Adcock, Christo Moskovsky, Peter Peterson

### Cowra Teams

John Brockwell, Val Brockwell, David Lander, Helene Lander

### Armidale Teams

Sharon Mayo, Greg Mayo, Michael Johnson, Michael Simes

### Pennant Hills Teams

Pauline Gumby, Warren Lazer, Johnno Newman, David Wiltshire

### Bathurst Central West Novice Tournament

See article above

### Gunnedah Congress

*Swiss Pairs:* Peter Tarlington, Peter Marshall  
*Teams:* Sharon Mayo, Greg Mayo, Ros Roworth, Ian Price

### Tumbarumba Congress

*Swiss Pairs:* Myra Katz, Darryl Almeida  
*Teams:* Noel Bugeia, George Stockham, Ken Colbert, Alex Hewat

### Parramatta Teams

Pauline Gumby, Warren Lazer, Avi Kanetkar, Ranjit Limaye

### Port Stephens Teams

Diana Ellis, Chris Hannan, David Snow, Denise Nisbet

### Southern Highlands Congress

*Open Swiss Pairs:* Ken Colbert, Alexander Hewat  
*Restricted Swiss Pairs:* Margaret Duncan, Elizabeth Loneragan  
*Teams:* Emlyn Williams, Lisa Ma, Vicky Lisle, Ian Lisle

### Trumps Spring Teams

Mathew Vadas, Michael Wilkinson, Derrick Browne, Joshua Wyner

## About us

Email us:

NSWBA Office: [office@nswba.com.au](mailto:office@nswba.com.au)

The Editor: [editor@nswba.com.au](mailto:editor@nswba.com.au)

Visit us:

Online - [www.nswba.com.au](http://www.nswba.com.au)

In person: 1<sup>st</sup> Floor 162 Goulburn St,  
East Sydney 2010

Call us:

Phone: 02-9264 8111

Doing business with us

ABN: ABN 61 000 438 648